

IMO3 Feeder

Automatic bowl feeder for all kinds of transfer machines

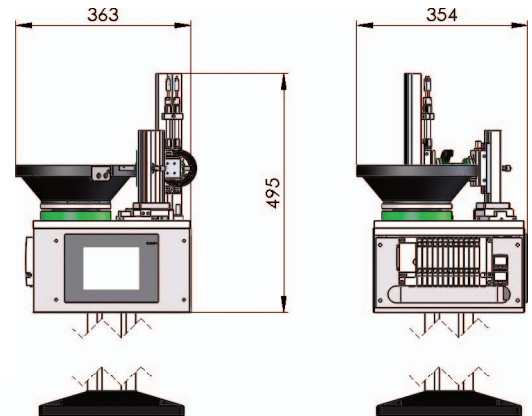

IMO3 Feeder :

- This standard auto-loader can be used for any cylindrical or screw machined parts from 0.02 to 0.25 inches in diameter and up to 2 inches in length.
- Loading rate up to 50 pieces a minute depending upon geometry of part.
- Face (side) recognition.
- Touch screen command.
- Easy teach in procedure.
- Multiple parts programs can be saved.
- Can be supplied as an independent unit or directly mounted on your machine.
- Built for industrial harsh environment.

LEMTRONIC

Route de la Greffaz 31
CH 1895 VIONNAZ

Tel : +41 (0)24 482 35 35
Fax : +41 (0)24 482 35 50

Follow us on



www.lemtronic.ch